



# MODEL 167

## PORTABLE MANUAL GROUT PUMP KIT

### 1 1/2" PORTS



- LIGHT WEIGHT PORTABLE GROUT SYSTEM
- PUMP GROUT, CEMENT, PEA GRAVEL
- DRY START LIFT TO 15'
- PUMP UP TO 50% SOLIDS
- LOW EMULSIVE & SHEER ACTION
- NON-CLOGGING FLOW THRU DESIGN
- EASY TO SET-UP, USE, CLEAN, AND MAINTAIN
- BUILT TOUGH FOR YEARS OF SERVICE
- LONG LIFE, REINFORCED PUMP DIAPHRAGMS

Here's the ideal hand operated pump for low pressure, low volume grouting operations. The "Grout Kit" is set up to pump grout, cement or similar high viscosity slurries. The kit is easily transported from site to site for those small jobs that make it costly to send a bigger system. The kit is ideal for well head filling, window and door frame grouting and machine rigging.

This grout pump can also be used as a dewatering pump. With a self prime suction lift of 15' and a pumping capacity of 18 gallons of water a minute it can make short work of pumping out pits, sumps and collecting waste liquids.

Kit models are available with an anodized aluminum pump or a marine grade bronze pump. Performance is the same but bronze is denser than aluminum and is recommended for customers who have a greater use for a grout kit.

**Performance:**

Static Suction Lift ..... 15hg/.5bars  
 Discharge Pressure ..... 8 psi/.55bars

**Ports Size:**

Inlet ..... 1 1/2" Male NPT  
 Discharge ..... 1 1/2" Female NPT

**Construction:**

Pump ..... Choice of:  
 (Wetted Parts) Anodized Aluminum  
 Marine Bronze  
 Diaphragms & Valves.....Choice of:  
 Nitrile  
 Viton®

Carry Board ..... 12" X 24" X 3/4"  
 Marine Grade Plywood

Hardware Material ..... Stainless Steel

Portable Pump Kit Hose ..... 20' Flexible Hose w/Quick  
 Clamp Fittings & Adapters

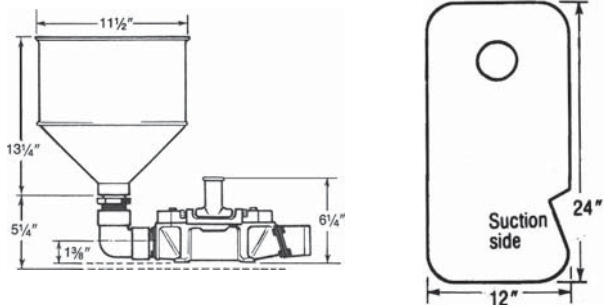

Description	Material	Port Sz	Weight Lb / Kg	Order No
Manual Pump Kit 18	Aluminum	1 1/2"	20 / 9.1	167AL-150
Manual Pump Kit 18	Bronze	1 1/2"	30.5 / 13.8	167BR-150
<b>Options</b>				
Diaphragm & Valves	Viton®			230-11318V

Viton® is a registered trademark of DuPont Dow Elastomers L.L.C.



**APPLICATIONS** The “Grout Kit” is set up to pump grout, cement or similar high viscosity slurries. It is just the right equipment for small grout jobs such as capping wells, setting machinery, filling metal door and window frames.

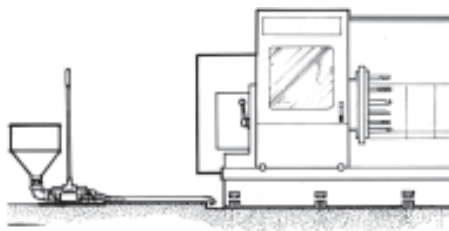
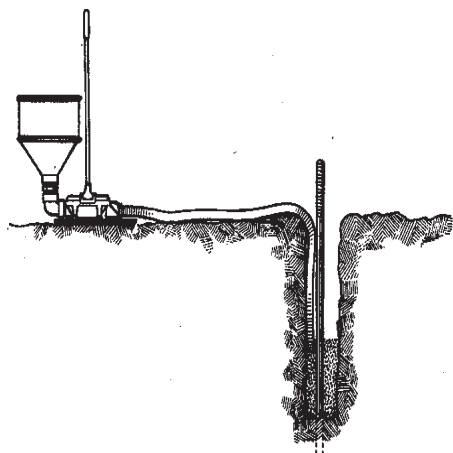

**OTHER APPLICATIONS** Because the Grout Kit employs the Edson self priming 217 pump it can also be used as a sump pump, liquid waste collection pump and a dewatering pump. Note below the divers applications this kit can be used for a bilge pump, holding-tank pump, wash-down pump on a small vessels and barges.

**INDUSTRIAL**

- Sump Pump-Outs
- Slurry Transfer
- Abrasive Pumping
- Oil Spill Cleanup
- Groundwater Removal

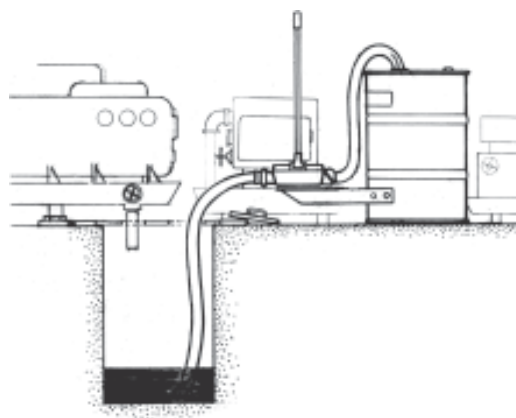

**ENVIRONMENTAL**

- Tank Pumpouts
- Grease & Oil Collections
- Skimming Pumping
- Asbestos Cleanups
- Oil-Water Separation
- Oil Spill Cleanup

**MUNICIPAL & UTILITY**

- Meter Pit Dewatering
- Manhole Dewatering Sewage
- Collection & Transfer
- Waste Water Skimming
- Drain Clean-out
- Utility Trunk Pump
- Fly Ash Cleanups
- Containment Transfer

