

EDSON® PUMPS

286EP-2HP PERISTALTIC PUMP OUT STATION

Installation and Operations Manual

Index:	Page 2 Description & Dimensions	Page 8 How to Pump Out
	Page 3 Installation	Page 9 Parts List
	Page 4 Plumbing	Page 10 Maintenance
	Page 5 Electrical	Page 12 Drawing - Installation Options
	Page 6 Wiring Diagram	Page 14 Pump Head
	Page 7 Hose Assembly	

IMPORTANT

**Motor IS Not Wired
It Can Be Wired Either 120 or 220 VAC.
(See Wiring Diagram)**



IMPORTANT Before Installing Pump Station

**Electrical Wiring - Wiring Diagram Is In a Plastic Pocket
Stuck To The Inside Of The Control Panel.**

A Model 286EP is built with different options that effect installation, performance and service.

- Make sure all the components listed on the packing slip are present
- Make sure the parts list attached to this manual includes all options listed.
- Fill in the important pump information below

SYSTEM SERIAL #

From Edson Serial # Sticker On Pump Frame

Components Description & Dimensions

Pump Assembly: 2hp/1ph/110-220v/60hz/tefc motor and a 20 to 1 ratio gear reducer coupled to a peristaltic pump. All arranged on a painted aluminum frame with 4 mounting flanges. A contact/timer control box is included.

Two 2" bronze elbow and a 2" X 1 1/2" 90° bronze reducer elbow are provided with the pump for use in connecting plumbing or hose to the inlet and discharge of the pump. fig.1

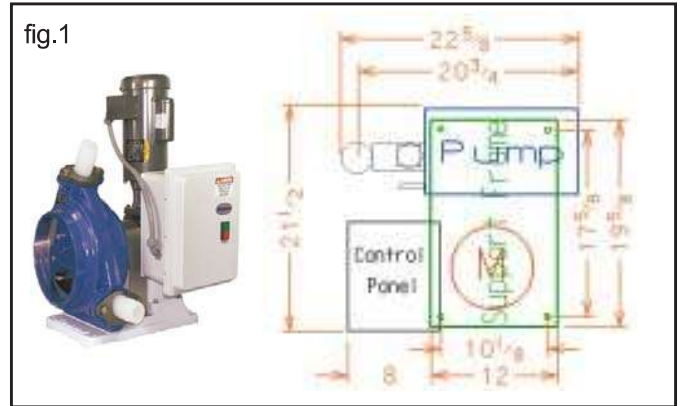

Pump Cover: White Fiberglass and Pump Out Sign. fig.2

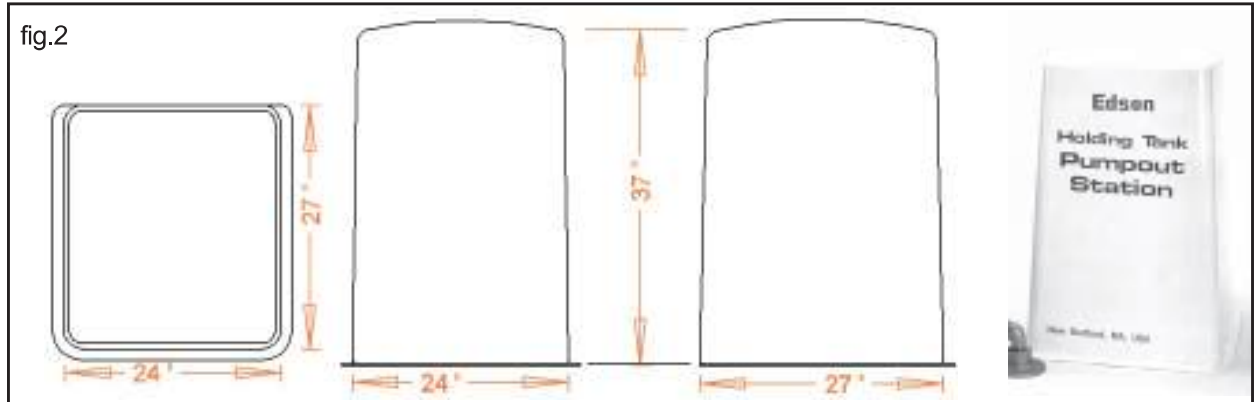

Hose Stand: White Powder Coated Aluminum with Start/Stop Buttons Installed, Operation Instructions and (4) 1/2" X 7" Aluminum Hex Head Mounting Bolts. fig.3

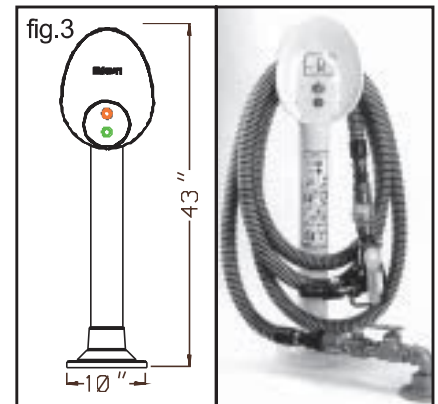

Hose Assembly: 50' X 1 1/2" Polyflex Hose, 90° Ball Valve, Sight Glass/Check Valve, Quick Clamp Adapter, Complete Set of Deck Adapters. fig.4



Hydrant: (Optional) 1 1/2" Bronze Check Valve, Plated Ball Valve and Quick Clamp Hose Adapter with Bronze Elbow and Close Nipple with Bronze Mounting Flange. fig.5

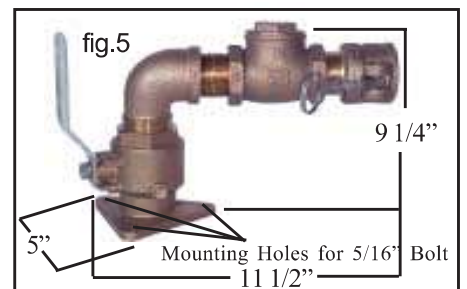

Installation Guidelines

WARNING

Factory Installed Motors Do Not Come Wired.

It is the responsibility of the purchaser to have the electrical service installed by a licensed electrician in accordance with the power requirements of the motor, the electrical service available and local electrical codes.

Failure to have the electricity installed correctly will result in damage to the pump and potential bodily injury, loss of life and property damage from electrical shock and fire.

The Pump:

1. Inspect the Pump Unit

- Check All Bolts - Make sure that all bolts on the pump are secure. fig.6
- Plumbing Fittings - All fittings including those supplied with the pump must be installed with thread sealant. fig.7

2. Locate the Pump Unit:

- Pump unit can be installed next to the pump out site or some distance away. See Drawing page 15 for options.
- Install for Maintenance - Install the pump in a manner that allows easy access for inspection & maintenance. Connect plumbing to the pump using unions or easily removed couplings. fig.7
- Install the pump in accordance with the performance specification. fig.8
- Install the Pump On a Smooth & Level Surface - In order to prevent unnecessary vibration and frame distortion, the pump unit must be installed on a relatively smooth and level surface.
- Bolt Pump Frame To Surface - Pump frame has 4 bolt down holes in the frame. Use these to secure the unit to the surface with lag bolts or similar fasteners. fig.9
- Allow Room for The Cover - See fig.2 for dimensions of the cover.

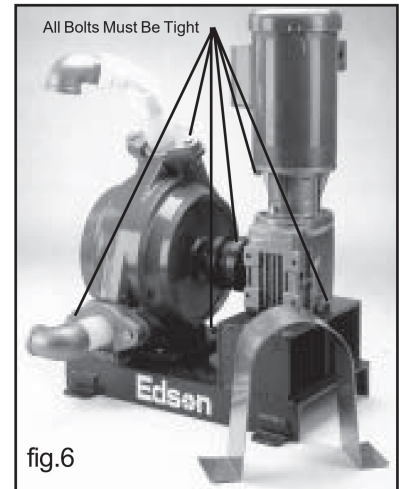

fig.6

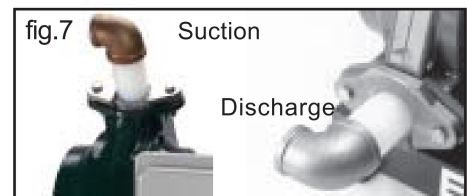

fig.7

CAUTION

Bolt Pump Securely To Level Surface

Peristaltic pumps are pulsating pumps. They can cause vibrations. The pump must be firmly bolted into position. Surface conditions may require the use of isolation pads on the frame.

CAUTION

Do Not Distort The Mounting Frame When Bolting Pump Unit In Place.

If the surface on which the pump unit is located is not smooth and level, bolting down the pump unit without shimming will distort the pump mounting frame. This may cause unnecessary vibration between the pump and the motor drive resulting in undue wear on the shaft bearings of both pump and motor drive.

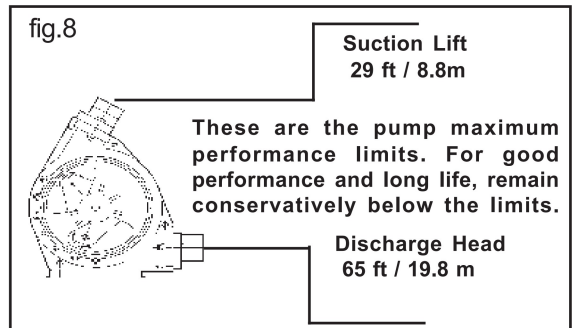

fig.8

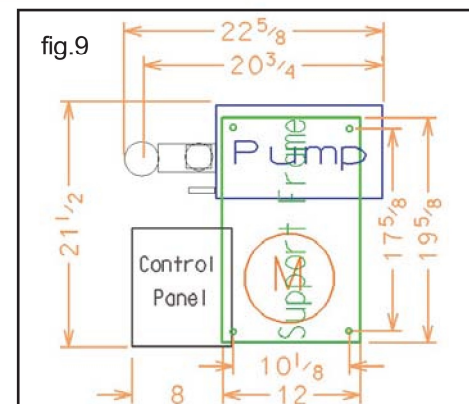

fig.9

The Hose Stand & Hydrant:

1. Inspect the Hose Stand

- Check the hose stand and 4 mounting bolts. Make sure stop/start switches are installed and are secure. fig. 10

2. Assemble The Hydrant per fig 11

- Use thread sealant on all components to insure all fittings are air tight.

Important

Plan for the electrical cable to be installed to the switches through the bottom of the hose stand and the 1 1/2" suction line to the bottom of the hydrant

3. Arrange the Stand and Hydrant at Pump Out Location:

- Position the hose stand and the hydrant so the hose can be easily wound and unwound from the stand. fig 11
- Position the hose stand and hydrant so that the 25 ft. hose can easily reach the boats to be pumped.
- Support hydrant with a plumbing hanger if necessary.
- Use the aluminum mounting bolts to secure the hose stand to the surface. If the 7" mounting bolts supplied can not be used, use appropriate substitutes. Aluminum is recommended.
- Secure hydrant to surface with appropriate hardware.

Install the Plumbing:

1. Install in Accordance with Local Codes & Standard Plumbing Practices

2. Use 1 1/2" or 2" ID Hose and/or Pipe on The Inlet and Minimum of 2" ID On the Discharge fig. 14

- Make all connections air tight on the suction line.
- Use long radius sewer sweep fittings for all elbows
- You can use elbows that come with the pump. fig 12 & 13
- Use thread sealant on all components to insure all fittings are air tight.

3. Pulsation - depending on the head conditions peristaltic pumps can generate considerable pulsation in both the suction and discharge lines .

- Insure all plumbing connections are secured to fixed structures.
- Insure that the pump unit is securely bolted in place.

4. Prevent Vapor locks

- Install plumbing so air travels up and out and is not trapped in pipes or fittings.

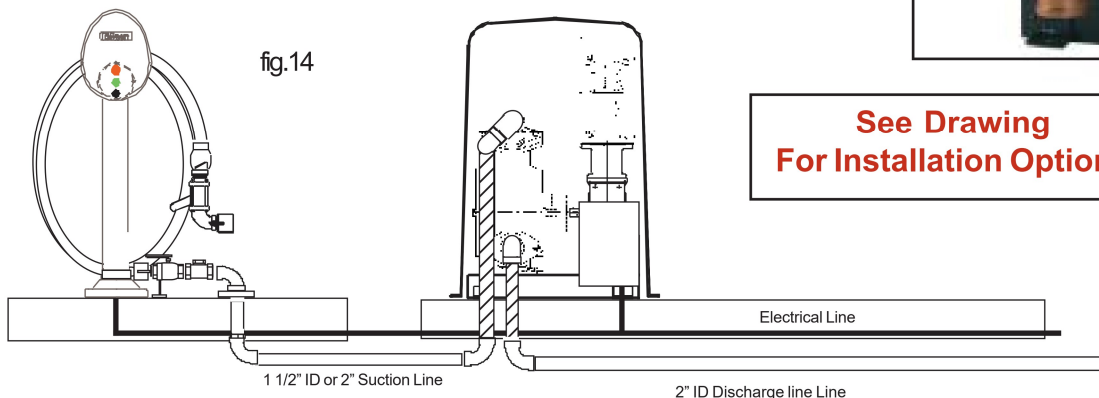
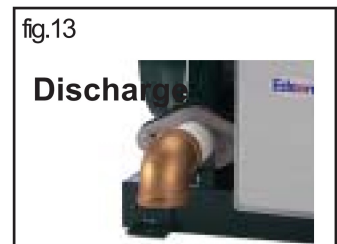
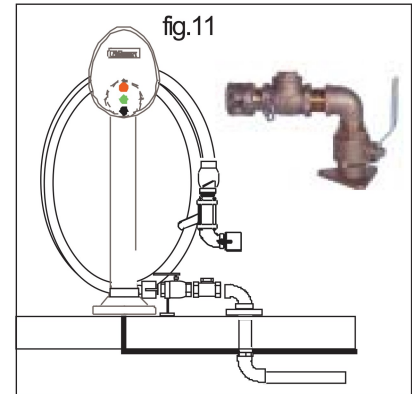
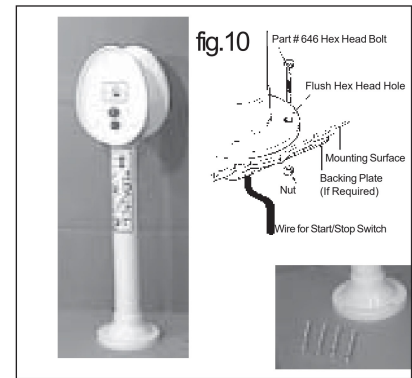

**See Drawing
For Installation Options**

Install Electrical:

Caution
All Electrical Connections Must Be Installed By a Licensed Electrician In Accordance With Local Codes

**Motor Can Be Wired for 120 Volt Or 240 Volt
 Follow Instructions On Wiring Diagram
 Copy Enclosed Inside Control Box**

Important
2 hp Motors Operating On 120 Volt Are Rated At Full Load AMPS of 23 & 12 AMPS for 240 Volt

- Wire motor per voltage diagram on motor legend plate.

Important
Direction of Motor Rotation Determines Direction Of Flow Through the Pump.

- Wire motor to console per wiring diagram.

Important
Requires (3) Wires To Connect Remote Start Stop Switches to Contact/Timer Control Box. Add 4th For Ground.

- Wire start & stop switch on hose stand to terminal strip in contact control blocks. Wire a ground from hose stand to control box mounting plate. fig. 16
- Wire multiple start stop stations to the contact timer according to fig.17
- Set the timer. (See Wiring Diagram Inside Panel Cover)

fig.15



Wire Motor For Desired Rotation. See Motor Legend Plate For Wiring Instructions.

fig.16

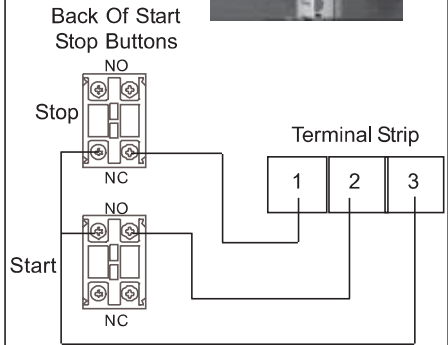
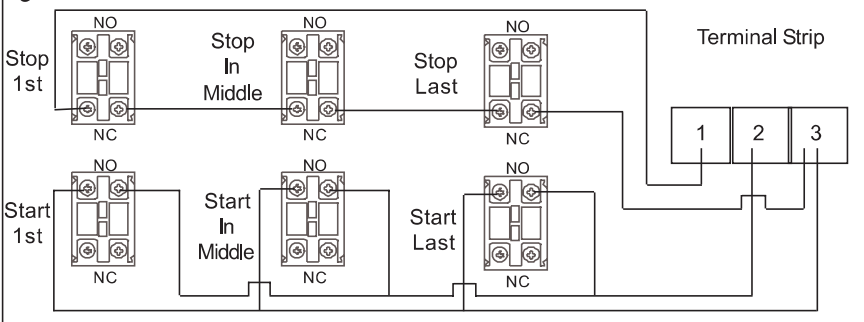

fig.17

Multiple Station Wiring Diagram.



Wiring Diagram Is Inside Control Panel

If not in plastic pocket call Edson Customer Service

508 995 9711

Install the Pump Out Hose Assembly

1. Assemble and Install the Pump Out Hose

- **Use Pipe Sealant On All Threads When Assembling Hose Components.**
- Part 158MF-150NY is an optional fitting used to adapt the thread on the hose end to quick clamp.
- 274-150 is a nozzle extension for use when pumping out portable toilets
- 273-150 & 125 are waste deck fitting adapters. They are screwed into a boat waste deck fitting so the hose can be clamped in place.
- 272QC-150 SG is a nozzle for use when either of the waste deck fitting adapters do not fit into the boat fitting. It is clamped onto the suction end of the hose and then held into the boat waste deck fitting.



Operation

Pumping Out

1. Make Sure Hydrant Ball Valve Is Open & Hose 90° Ball Valve is Closed.

2. Prepare The Waste Deck Fitting On the Boat.

- Remove the cap from the deck fitting.
- Screw in a deck adapter, 1 1/2" or 1 1/4".
- If neither fit, clamp the universal nozzle to the hose.
- If pumping out a portable holding tank or bucket, clamp the potty wand to the hose.

Waste Deck Adapters



fig. 25

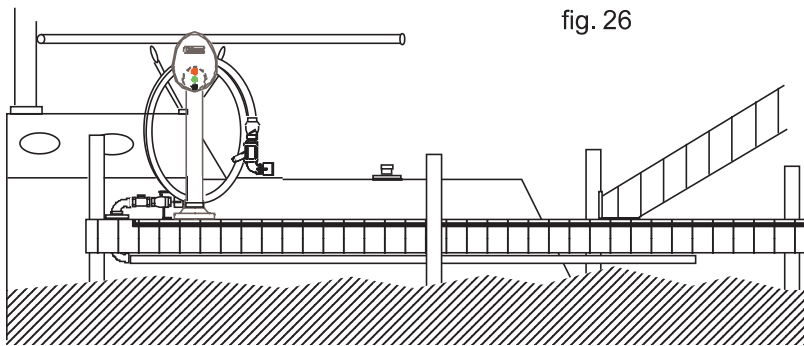

fig. 26

3. Turn On The Pump Out System.

- Push the green start button

4. Connecting The Hose To The Boat

- Unwind the hose all the way from the hose stand.
- Clamp the hose to the deck adapter or hold the universal nozzle in the deck fitting.

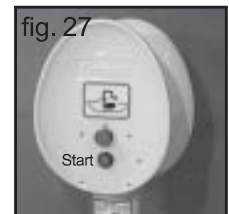

fig. 27

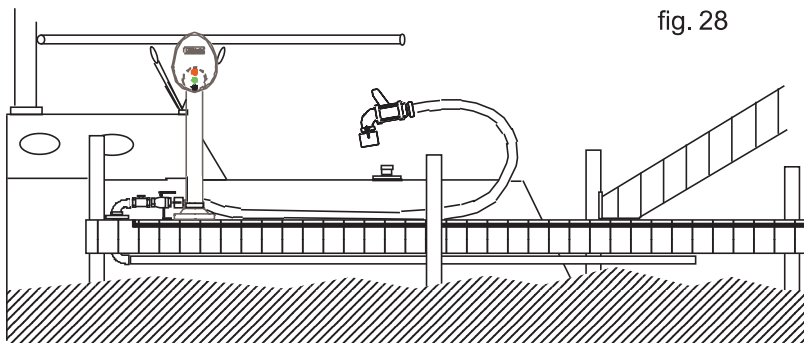

fig. 28

5. Open The Ball Valve Slowly & Pump Out.

- When the holding tank is empty, close the ball valve.
- Pump water through your toilet into the holding tank.
- Pump out again. This procedure rinses the entire system and helps to prevent odor.
- Close The Ball Valve & Disconnect The Hose

6. Flush the Hose.

- Put the hose into water & open the ball valve long enough to the flush the hose and plumbing.
- Lift the hose and close the ball valve.
- Push the Red Stop Button.

7. Clean Up.

- Curl the hose onto the hose stand.
- Secure the boat deck fitting.
- Rinse the deck and pump out with water.
- Wash your hands.

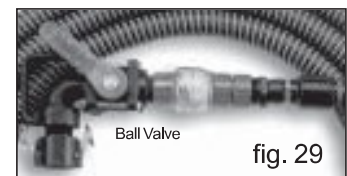

Ball Valve

fig. 29

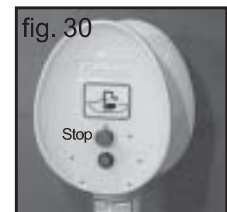
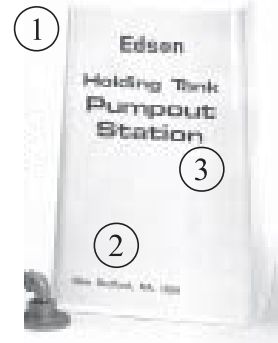

fig. 30

Parts

Enclosure

- 1 B-808 White Fiberglass Enclosure
- 2 160-A-1421-A Edson New Bedford MA Sign
- 3 160-A-1421-C Holding Tank Pump Out Sign



Enclosure

Hose Stand 260-284

- 4 646-7HEX Hex Head Aluminum Bolts
- 5 161-A-1705-FL Momentary Mushroom Switch Red
- 6 161-A-2043 Momentary Switch Green
- 7 160-A-1693-2 Pump-Out Instruction Sign
- 8 160-A-1693-3 Pump-Out Logo Sign



Hose Stand 260-284

Bronze Hydrant 270BR-150 (Optional)

- 9 152MF-150BR Quick Clamp Adapter 1 1/2" FQC X MNPT
- 10 269BR-150 Bronze Swing Check Valve
- 11 160-A-1708 1 1/2" Close Nipple, Bronze
- 12 160-A-1711 90 Degree Street Elbow Bronze
- 13 160-A-2551-150 1 1/2" Tri Flange Seacock
- 14 153QP-150NY Quick Clamp Plug (Not Shown)



Bronze Hydrant 270BR-150

Hose Assembly 261-25-150

- 15 262-25-150 Hose
- 16 269CL-150 Clear Swing Check Valve
- 17 264-90-150 90 Degree Ball Valve 1.5"
- 18 152FM-150NY Quick Clamp Adapter 1 1/2" FQC X MNPT
- 19 158MF-150NY Quick Clamp Adapter 1 1/2" MQC X FNPT



Hose Assembly 261-25-150
Pump Out Adapters

Pump Out Adapters

- 20 273-150 1 1/2" Deck Adapter
- 21 273-125 1 1/4" Deck Adapter
- 22 272QC-150-SG QC Pump Out Nozzle With Splash Guard
- 23 274-150 Potty Wand



Pump Assembly

- 24 161-A-2324 2 HP Contact Timer w/ 24 Volt Transformer
- 25 161-A-1910 Peristaltic Pump See Manufacturers Parts Drawing Page 10
- 26 161-A-1977 Helical Gear Reducer
- 27 161-A-1912 2HP Single Phase 120/240 V, 3450RPM,56C, TEFC
- 28 161-C-764 Pump Mounting Platform AND
161-D-288 Reducer Adapter
- 29 Coupling, Motor to Pump (3 Parts)
 - 29a 161-A-1914 Coupling Flexible Insert
 - 29b 161-A-1975 Coupling Section on Pump Modified
 - 29b 161-A-1913 Coupling Section on Reducer 1" Bore
 - 29c 161-B-1198 Coupling Cover Not Shown



Pump Assembly

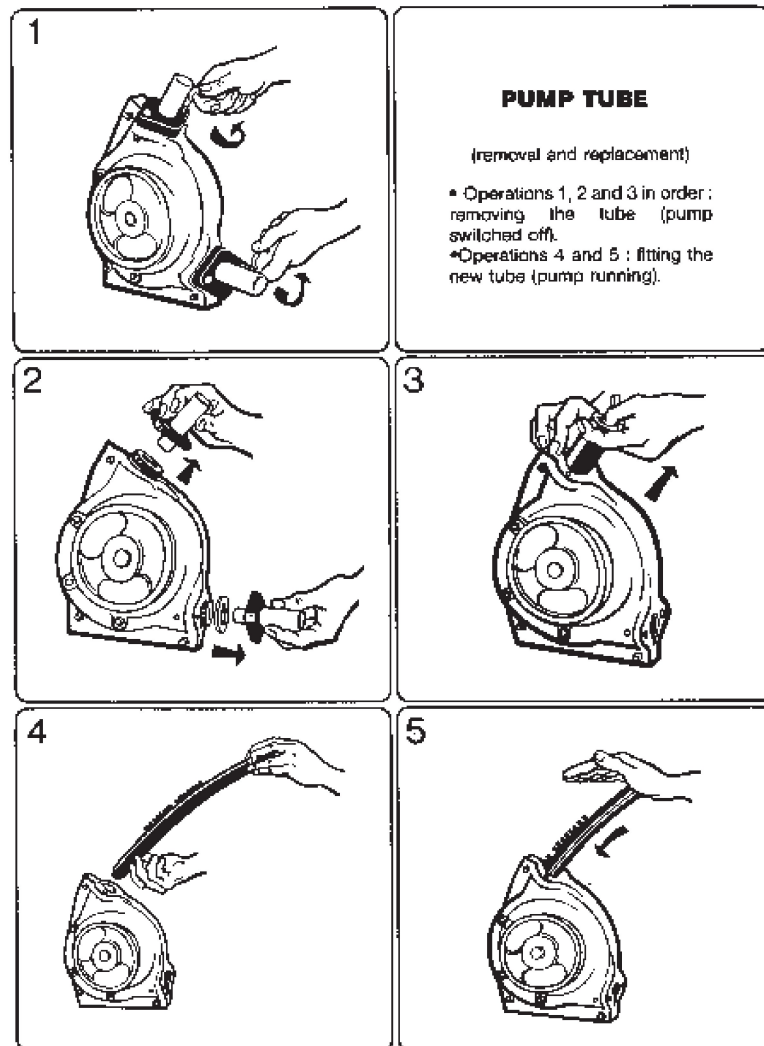

GENERAL MAINTENANCE INSTRUCTIONS

REMOVING AND REPLACING THE TUBE

The diagrams above show how to perform these two operations (figures 1 to 5 inclusive).

DISASSEMBLING THE PUMP CASING

Although replacing the pump hose does not require the dismantling of the casing, it may happen that internal parts of same have to be checked, cleaned or replaced.

In such case, we recommend following procedure :

- Remove counter-flanges.
- Unscrew nuts and screws holding stator set together.
- Remove the open part of casing by pulling it towards you.
- If there is any difficulty in separating the two stators, insert a piece of wood or a blunt tool handle into the suction and discharge openings of the pump. Never use a hammer or a sharp tool which might cause damage.
- Flush down casing to eliminate abrasive or corrosive substances.
- Check that the rollers turn easily on their spindles. If they have seized up, replace the rollers.
- Replace the brake tube if it is worn.

N.B. : When ordering spare parts, refer to the technical sheet for the pump model in question.

Grease Hose Periodically See Instructions Attached Page 11



Maintenance

WARNING

Turn Off & Lock Out Electrical Service To The Pump Motor Before Performing Any Pump Maintenance .

Failure To Do This Could Result in Bodily Injury

1. Greasing The Hose

- Turn off and lock out all electrical power to the peristaltic pump.
- Remove the main fiberglass cover from over the pump unit.
- Remove the clear plastic cover from the face of the pump.
- Using the grease gun and the long nozzle, apply a bead of grease along the surface of the hose where the rollers make contact. Apply grease to the exposed surface of the rollers.

